

CMOS Circuit for Analog Quartz Clocks with Bipolar Stepping Motor Drive

Description

The H1344 is a low power 32kHz analog clock integrated circuit designed in CMOS technology to drive a bipolar stepping motor. A set of capacitors is provided on chip to be connected, in any combination, to the two oscillator terminals, with a maximum total capacitance of 48pF. Both the motor pulse period and the motor pulse width are mask-programmable (see page 6 for already available options). For versions v143 and v221, the TEST1 and TEST2 pins are only for test and must not be used in the application.

Applications

- Stepper Motor Driver for time-switches
- Analog clocks

Features

- 32kHz quartz oscillator
- Integrated capacitors, mask selectable
- Single battery operation
- 0.7 μ A typical current consumption
- Low resistance outputs for bipolar stepping motor
- Mask options for pad designation, motor period and pulse width, alarm frequency, modulation and duty cycle
- Alarm output function compatible with either NPN or PNP-driver transistors
- Alarm input function
- 1024Hz output on AL_{IN} pad for oscillator frequency verification
- Fast test function
- ESD protected terminals

Functional Diagram

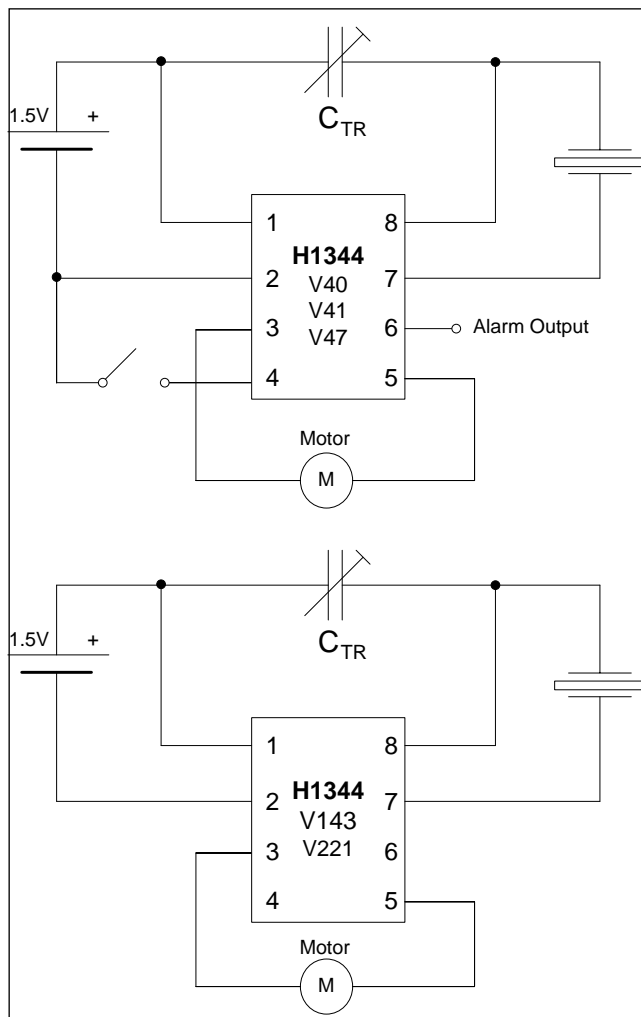

Fig. 1

Pin Assignment

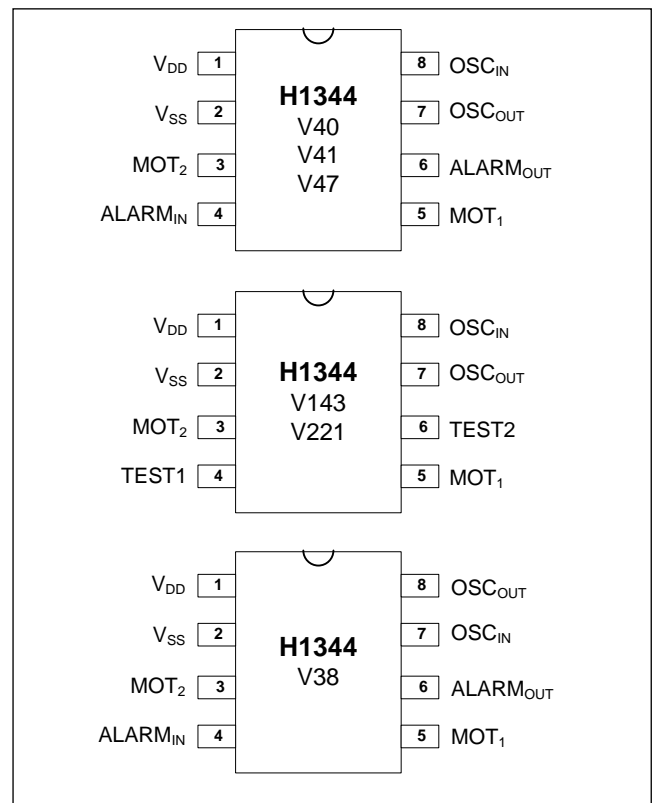

Fig. 2

Absolute Maximum Ratings

Parameter	Symbol	Min.	Max.	Units
Supply voltage range	$V_{DD} - V_{SS}$	-0.3	+5	V
Input voltage	V_{IN}	V_{SS}	V_{DD}	V
Storage temperature	T_{STOR}	-55	+125	°C

Table 1

Stresses beyond these listed maximum ratings may cause permanent damage to the device. Exposure to conditions beyond specified operating conditions may affect device reliability or cause malfunction.

Handling Procedures

This device contains circuitry to protect the terminals against damage due to high static voltages or electrical fields. However, it is advised that normal precautions be taken to avoid application of any voltage higher than maximum rated voltages to this circuit.

Recommended Operating Conditions

Parameter	Symbol	Value	Units
Ambient temperature	T	25	°C
Quartz frequency	F_Q	32768	Hz
Quartz series resistance	R_Q	30	k Ω
Motor coil resistance	R_M	200	Ω
Positive supply	V_{DD}	1.55	V
Negative supply	V_{SS}	0	V

Table 2

Operating Conditions

Parameter	Symbol	Min.	Typ.	Max.	Units
Operating temperature	T_{OPR}	-20		+70	°C
Quartz series resistance			30	50	k Ω
Trimmer capacitance	C_{TR}	1.5		30	pF

Table 3

Electrical and Switching Characteristics

at recommended operating conditions (valid unless otherwise specified)

Parameter	Symbol	Test	Min.	Typ.	Max.	Units
Supply voltage	V_{DD}	operating	+1.1		+1.8	V
Supply current	I_{DD}	without, AL_{IN} open		0.7	2.0	μ A
Motor Output						
Current into load	I_M	$V_{DD} = 1.2V, R_M = 200\Omega$	± 4.0			mA
Pulse period	T_1			Mask option*		s
Pulse width	t_w			Mask option*		ms
Alarm Output						
Frequency	f_A			Mask option*		Hz
Modulation	f_{A1}			Mask option*		Hz
Cycle time	T_2			Mask option*		s
Pulse duration	t_P			Mask option*		s
Output current for driving NPN-transistor	I_{ALOUTN}	$V_{DD} = 1.2V, V_{OL} = 0.2V$	0.5			μ A
Output current for driving PNP-transistor	I_{ALOUTN}	$V_{DD} = 1.2V, V_{OH} = 0.7V$	0.3			mA
Output current for driving PNP-transistor	I_{ALOUTN}	$V_{DD} = 1.2V, V_{OL} = 0.5V$	0.3			mA
Output current for driving PNP-transistor	I_{ALOUTN}	$V_{DD} = 1.2V, V_{OH} = 1.0V$	0.5			μ A
Alarm Input						
Test In/Output						
Alarm input delay	t_{ALD}		125		570	ms
Test frequency	f_T			1024		Hz
Input current (alarm)	I_{IN}	Input at $V_{SS}, V_{DD} = 1.4V$	-1	-5	-10	μ A
Input current	I_{IN}	Input at V_{DD}	1	15	30	μ A
Oscillator						
Build-up time	t_{START}	$V_{DD} = 1.2V$			2	s
Stability against supply voltage variation	$\frac{\Delta f}{f} \times V_{DD}$	$1.1V \leq V_{DD} \leq 1.8V$		5	12	ppm/V
Output capacitance	C_{OUT}			Mask option*		pF
Input capacitance	C_{IN}			Mask option*		pF

Table 4

* See "Available options" on page 6.

Timing Waveforms

Motor Output Waveform

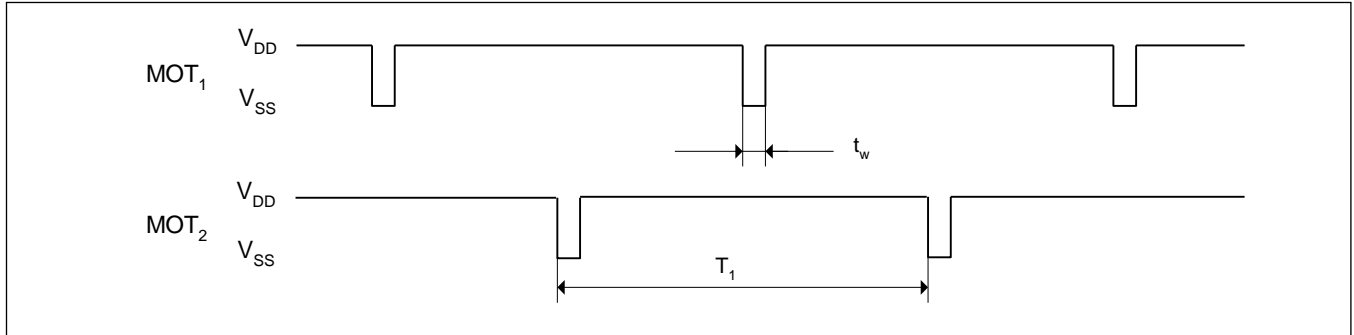

Fig. 3

Alarm Output Waveform

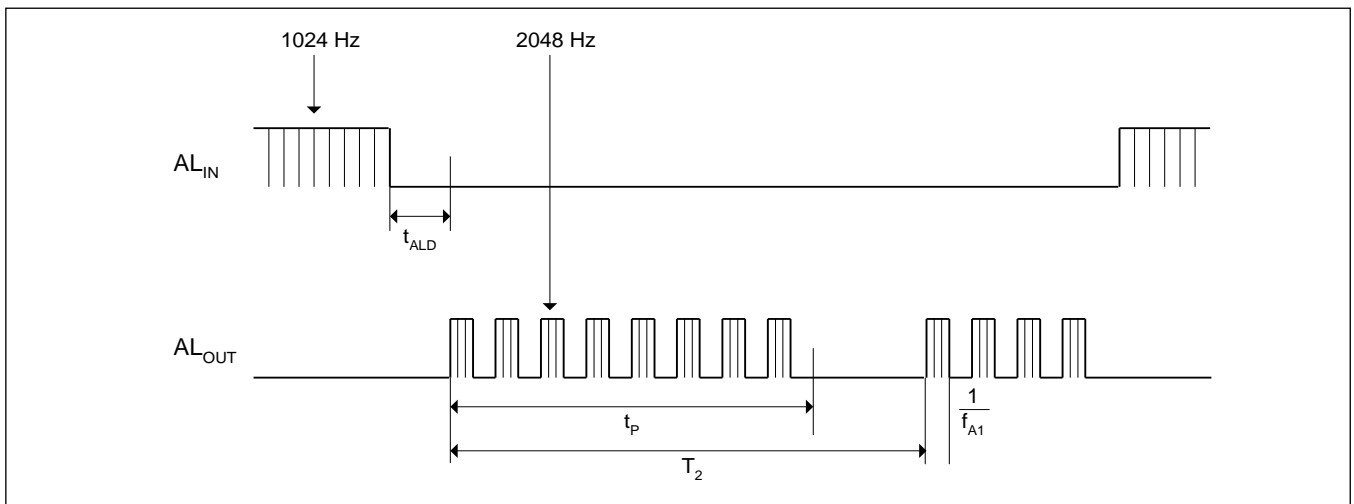

Fig. 4

Functional Description

Oscillator and Frequency Divider

The quartz oscillator consists of an inverter, internal feedback resistance to bias the input and integrated capacitors. The values of the integrated capacitors are selectable by metal mask. The oscillator is designed for 32768Hz.

Motor Drive Output

The circuit contains two push-pull output buffers for driving bipolar stepping motors. Between two pulses, both P-channel transistor of the other buffer are conducting. The outputs are protected against inductive voltage spikes with diodes to both supply pins.

Both the motor pulse period and motor pulse width are programmable by metal mask over a wide range of values (see page 6 for available options).

Alarm Output

The alarm is activated by connecting $ALARM_{IN}$ to V_{SS} and is deactivated by opening the connection. A metal mask option is available to program a continuous activation of the alarm output.

The alarm output driver contains a push-pull output buffer to drive an external sound source by means of an external bipolar transistor. A metal mask option is available to allow the use of NPN or PNP-transistors.

The tone frequency, modulation frequency, modulation frequency and cycle time (ON/OFF time) are metal mask selectable.

Test Mode

The $ALARM_{IN}$ pin fulfills three functions:

- For normal operation, the $ALARM_{IN}$ pin is left open. The circuit provides a square wave signal of 1024Hz, which can be used to tune the oscillator.
- If the pin is connected to V_{SS} , the alarm signal is provided at pin 6.
- If the $ALARM_{IN}$ pin is connected to V_{DD} , all output frequencies are increased by a factor of 64, the alarm modulation of $f_{A1} = 8\text{Hz}$ and $f_A = 2\text{kHz}$ are suppressed.

Test configuration

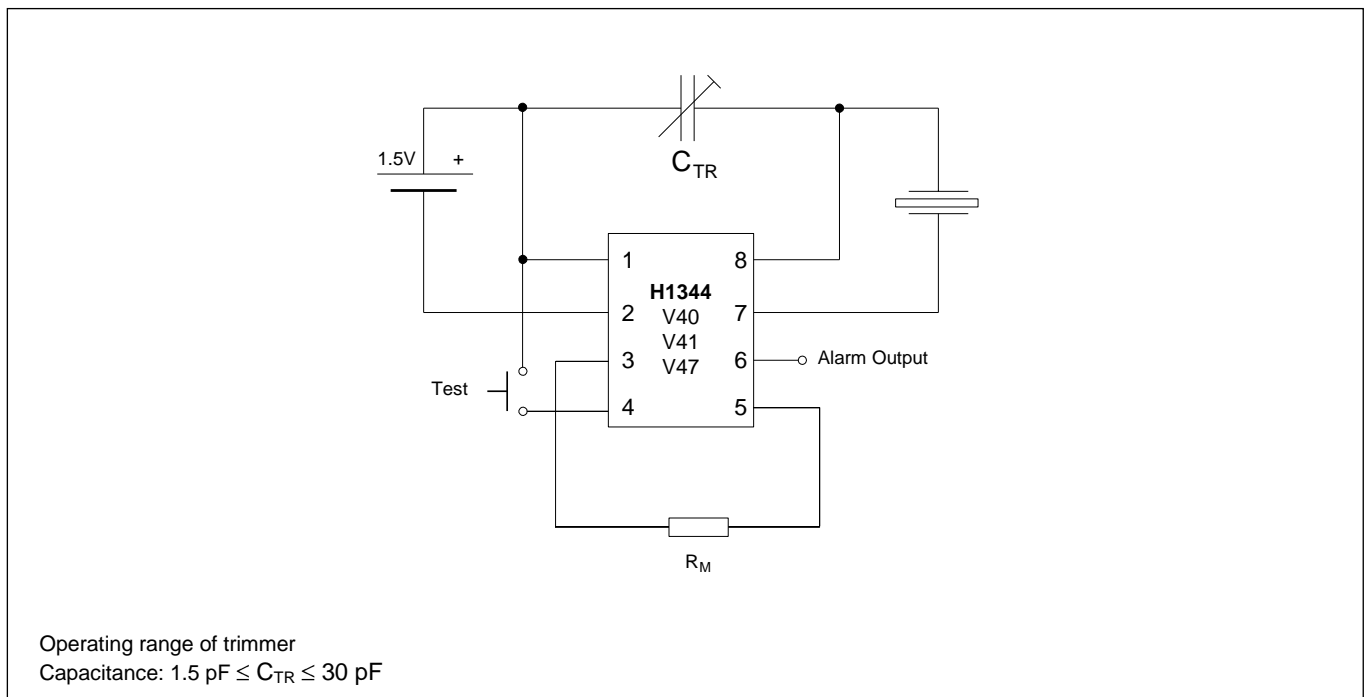

Fig. 5

Pad Location Diagram

All dimensions in μm

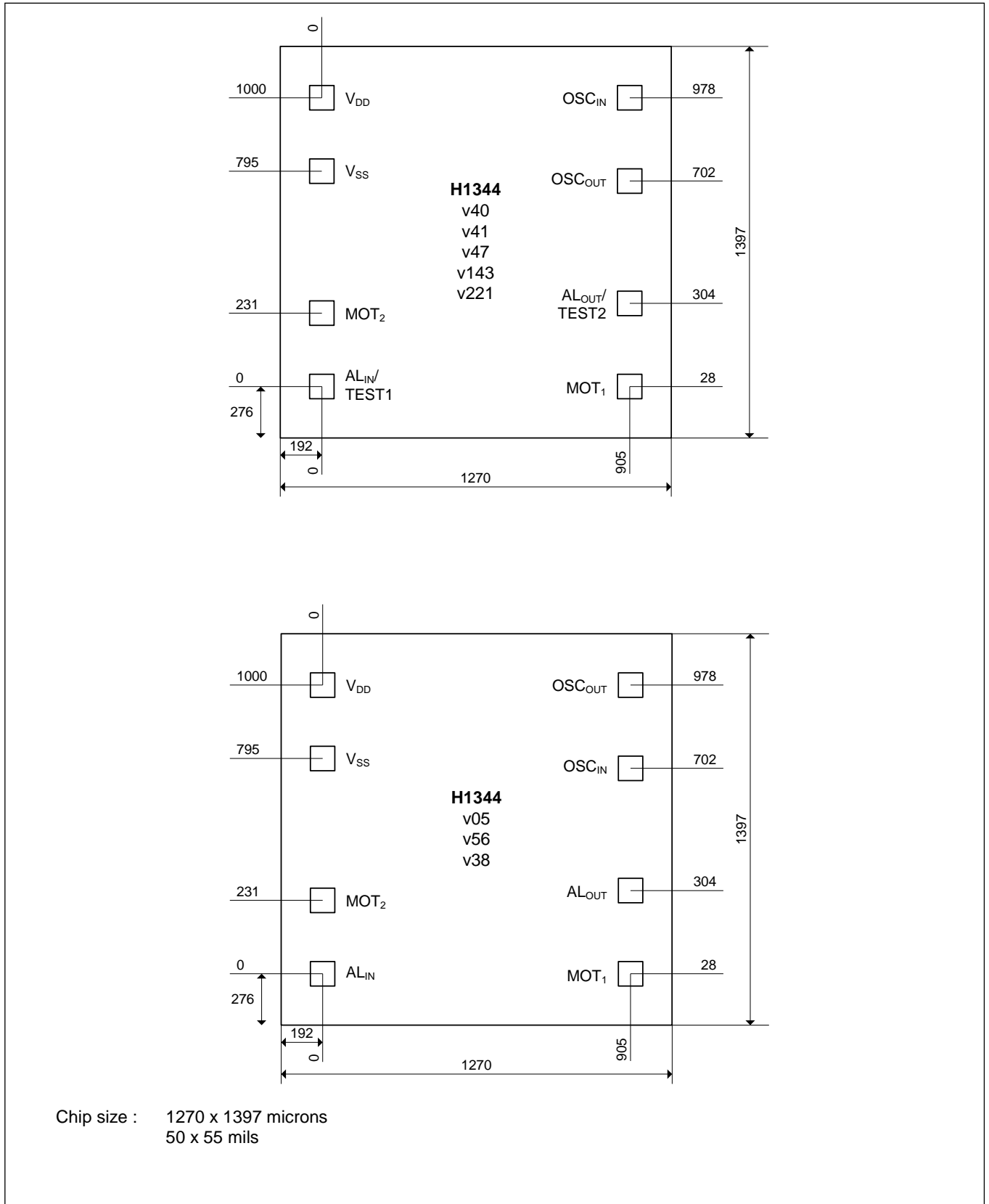

Fig. 6

Ordering Information

Versions

The versions below are considered standards. For the other delivery form, please contact EM Microelectronic-Marin S.A. Please make sure to give the complete part number when ordering.

Part Number	Version	Motor		Alarm Output				Integrated Capacitance		Alarm Output Transistor	Package	Delivery Form
		Period (T_1)	Pulse width (t_w)	Frequency (f_A)	Modulation (f_{A1})	Cycle time (T_2)	Pulse duration (t_p)	(C_{IN})	(C_{OUT})			
EM1344V38DL8A+	V38	2s	46.8ms	2048Hz	8Hz	4s	1s	3pF	28pF	NPN	DIL8	Stick
EM1344V38DLWS11											Dice	Sawn wafer
EM1344V40DL8A+	V40	2s	46.8ms	2048Hz	8Hz	4s	1s	3pF	20pF	NPN	DIL8	Stick
EM1344V40DLWS11											Dice	Sawn wafer
EM1344V41DL8A+	V41	2s	23.4ms	2048Hz	8Hz	4s	1s	3pF	20pF	NPN	DIL8	Stick
EM1344V41DLWS11											Dice	Sawn wafer
EM1344V47DL8A+	V47	2s	31.24ms	2048Hz	8Hz	1s	0.5s	3pF	20pF	NPN	DIL8	Stick
EM1344V47DLWS11											Dice	Sawn wafer
EM1344V143DL8A+	V143)	2s	46.8ms	--	--	--	--	17pF	25pF	--	DIL8	Stick
EM1344V143SO8A+											8 pin SOIC	Stick
EM1344V143SO8B+											8 pin SOIC	Tape & Reel
EM1344V221DL8A+	V221	2s	1s	--	--	--	--	9pF	20pF	--	DIL8	Stick
EM1344V221SO8A+											8 pin SOIC	Stick
EM1344V221SO8B+											8 pin SOIC	Tape & Reel

*) Supply voltage range of 1.4V – 2.8V

EM Microelectronic-Marin SA (EM) makes no warranty for the use of its products, other than those expressly contained in the Company's standard warranty which is detailed in EM's General Terms of Sale located on the Company's web site. EM assumes no responsibility for any errors which may appear in this document, reserves the right to change devices or specifications detailed herein at any time without notice, and does not make any commitment to update the information contained herein. No licenses to patents or other intellectual property of EM are granted in connection with the sale of EM products, expressly or by implications. EM's products are not authorized for use as components in life support devices or systems.